

Gamma Sources



RITVERC JSC

10, Kurchatova str.,
St. Petersburg, Russia
194223

Tel: +7 812 297 44 63
+7 812 297 22 69
Fax: +7 812 297 22 69

Email: info@ritverc.com
Url: www.ritverc.com

²²Na Gamma Sources

²²Na is incorporated in a light ceramic matrix and sealed in a welded stainless steel capsule. GNa2.27 source is also available in titanium capsule.

Recommended working life: 15 years. Recommended working life of the control source in case of using in control devices is 5 years.

Certificates

IAEA Special Form Certificate No D/0098/S-96 (Rev.0) (for GNa2.12, GNa2.13, GNa2.14, GNa2.15, GNa2.27)

D × H, mm	d × h, mm	Nominal activity *		ISO classification	Code
		mCi	MBq		
3 × 3	2.1 × 1.5	0.0027–0.27	0.1–10	C64344	GNa2.11
3 × 10	2.1 × 1.5	0.0027–0.27	0.1–10	C64444	GNa2.12
4 × 10	3.1 × 1.5	0.0027–0.27	0.1–10	C64444	GNa2.13
7 × 10	5.2 × 2.5	0.0027–0.27	0.1–10	C64444	GNa2.14
8 × 5	4 × 1.2	0.0027–0.27	0.1–10	C64444	GNa2.15
10 × 5	8.5 × 1	0.0027–0.27	0.1–10	C64444	GNa2.16
12 × 3	8.5 × 1	0.0027–0.27	0.1–10	C64444	GNa2.17
30 × 4.5	8.5 × 1	0.0027–0.27	0.1–10	C64444	GNa2.18
10 × 4	4 × 1.2	0.0027–0.27	0.1–10	C64444	GNa2.19
3 × 5	2.1 × 1.5	0.0027–0.27	0.1–10	C66444	GNa2.27

* — tolerance -10 ÷ +20 %

Other activities are available on request

Sources can be supplied complete with holders. For details see [page 20](#)

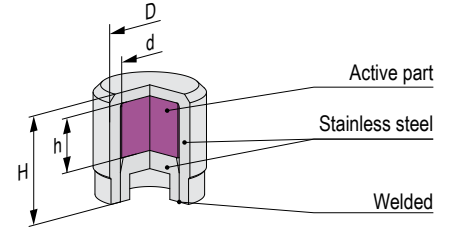

11

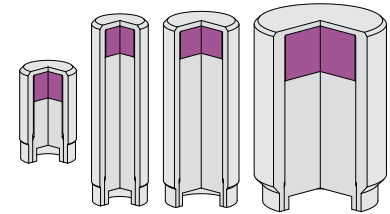
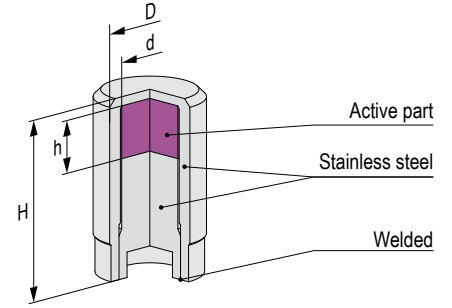

27 12 13 14

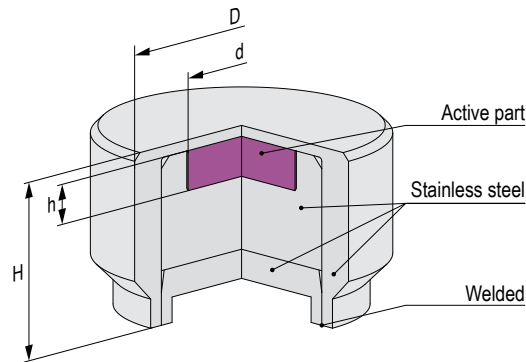

15

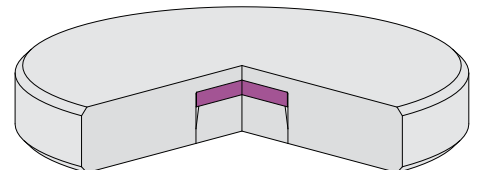
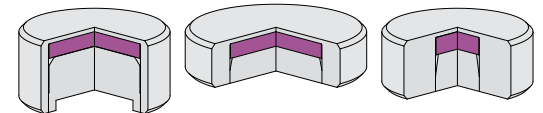
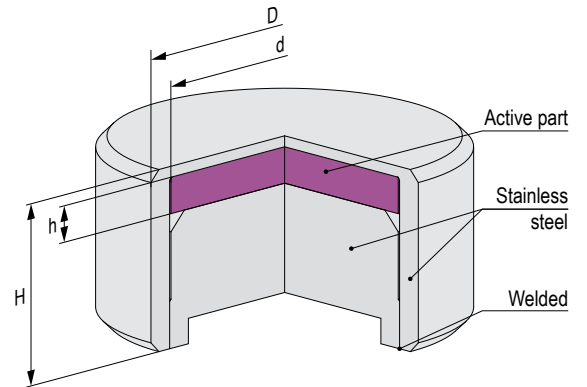

16 17 19
18

⁵⁷Co Gamma Sources

⁵⁷Co is incorporated in a light ceramic matrix and sealed in a welded stainless steel capsule. GCo7.27 source is also available in titanium capsule.

Recommended working life: 15 years.

Certificates

IAEA Special Form Certificate No D/0098/S-96 (Rev.0) (for GCo7.12, GCo7.13, GCo7.14, GCo7.15, GCo7.27)

D × H, mm	d × h, mm	Nominal activity *		ISO classification	Code
		mCi	MBq		
3 × 3	2.1 × 1.5	1-300	37-11100	C64344	GCo7.11
3 × 10	2.1 × 1.5	1-300	37-11100	C64444	GCo7.12
4 × 10	3.1 × 1.5	1-300	37-11100	C64444	GCo7.13
7 × 10	5.2 × 2.5	1-300	37-11100	C64444	GCo7.14
8 × 5	4 × 1.2	1-300	37-11100	C64444	GCo7.15
10 × 5	8.5 × 1	1-300	37-11100	C64444	GCo7.16
12 × 3	8.5 × 1	1-300	37-11100	C64444	GCo7.17
30 × 4.5	8.5 × 1	1-300	37-11100	C64444	GCo7.18
10 × 4	4 × 1.2	1-300	37-11100	C64444	GCo7.19
3 × 5	2.1 × 1.5	1-300	37-11100	C66444	GCo7.27

* — tolerance -10 ÷ +20 %

Other activities are available on request

Sources can be supplied complete with holders. For details see [page 20](#)

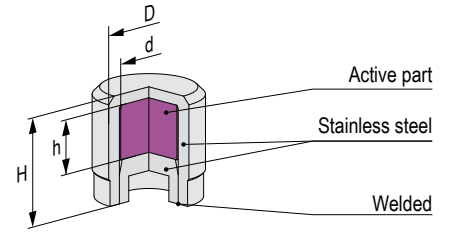

11

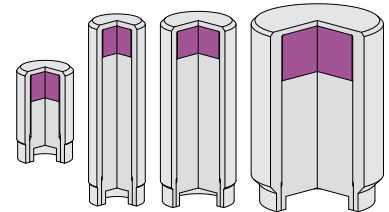
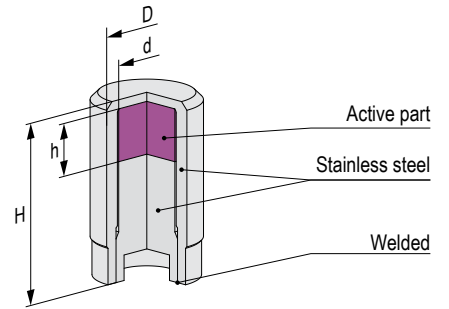

27 12 13 14

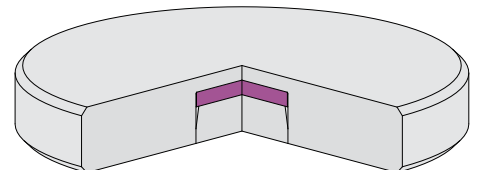
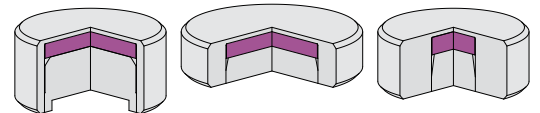
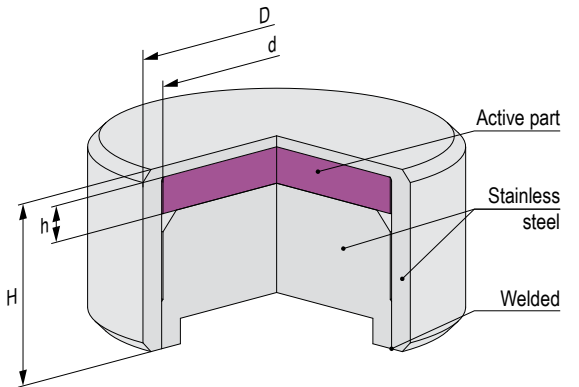

16 17 19

18

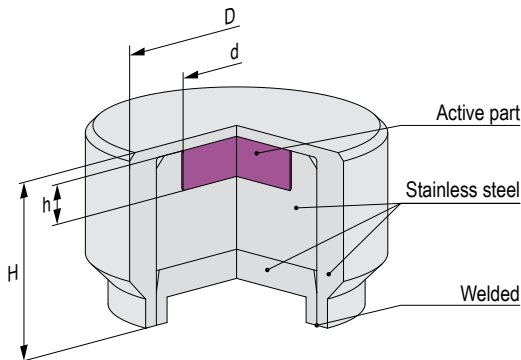

15

⁶⁰Co Gamma Sources

⁶⁰Co is incorporated in a light ceramic matrix and sealed in a welded stainless steel capsule. GCo0.27 source is also available in titanium capsule.

Recommended working life: 15 years.

Certificates

IAEA Special Form Certificate No D/0098/S-96 (Rev.0) (for GCo0.12, GCo0.13, GCo0.14, GCo0.15, GCo0.27)

D × H, mm	d × h, mm	Nominal activity *		ISO classification	Code
		mCi	MBq		
3 × 3	2.1 × 1.5	0.0027–0.135	0.1–5	C64344	GCo0.11
3 × 10	2.1 × 1.5	0.0027–0.135	0.1–5	C64444	GCo0.12
4 × 10	3.1 × 1.5	0.0027–0.135	0.1–5	C64444	GCo0.13
7 × 10	5.2 × 2.5	0.0027–0.135	0.1–5	C64444	GCo0.14
8 × 5	4 × 1.2	0.0027–0.135	0.1–5	C64444	GCo0.15
10 × 5	8.5 × 1	0.0027–0.135	0.1–5	C64444	GCo0.16
12 × 3	8.5 × 1	0.0027–0.135	0.1–5	C64444	GCo0.17
30 × 4.5	8.5 × 1	0.0005–0.135	0.0185–5	C64444	GCo0.18
10 × 4	4 × 1.2	0.0027–0.135	0.1–5	C64444	GCo0.19
6 × 7	3 × 3.3	0.0027–0.135	0.1–5	C65546	GCo0.25**
3 × 5	2.1 × 1.5	0.0027–0.135	0.1–5	C66444	GCo0.27

* — tolerance -10 ÷ +20 %

** — for details see [page 19](#)

Other activities are available on request

Sources can be supplied complete with holders. For details see [page 20](#)

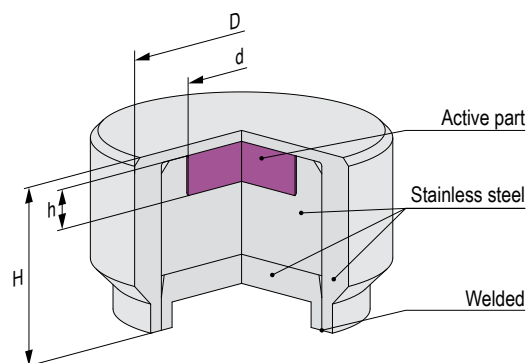

15

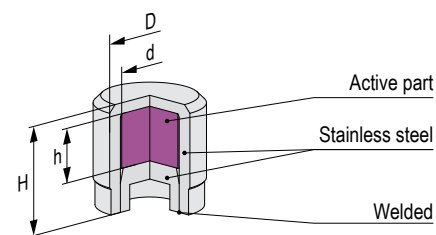

11

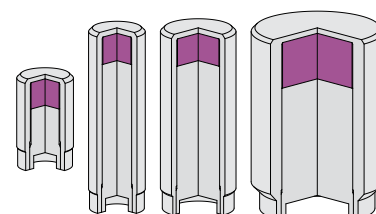
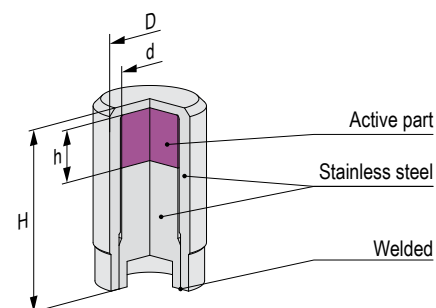

27 12 13 14

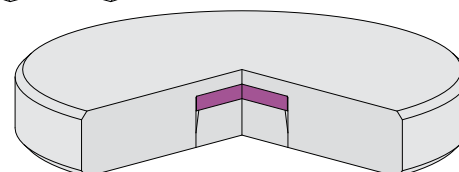
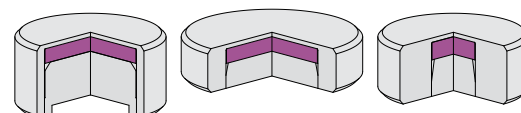
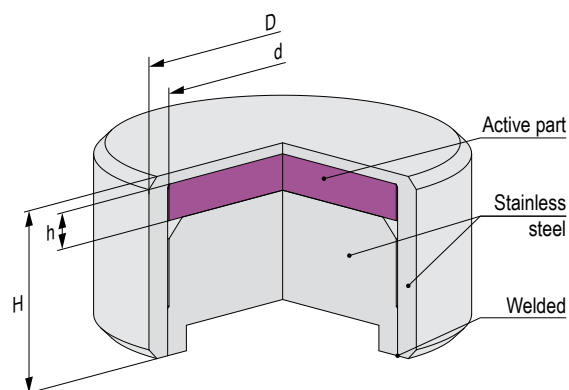

16 17 19

18

⁶⁵Zn Gamma Sources

⁶⁵Zn is incorporated in a light ceramic matrix and sealed in a welded stainless steel capsule. GZn5.27 source is also available in titanium capsule.
Recommended working life: 15 years.

Certificates

IAEA Special Form Certificate No D/0098/S-96 (Rev.0) (for GZn5.12, GZn5.13, GZn5.14, GZn5.15, GZn5.27)

D × H, mm	d × h, mm	Nominal activity *		ISO classification	Code
		mCi	MBq		
3 × 3	2.1 × 1.5	0.0027–0.135	0.1–5	C64344	GZn5.11
3 × 10	2.1 × 1.5	0.0027–0.135	0.1–5	C64444	GZn5.12
4 × 10	3.1 × 1.5	0.0027–0.135	0.1–5	C64444	GZn5.13
7 × 10	5.2 × 2.5	0.0027–0.135	0.1–5	C64444	GZn5.14
8 × 5	4 × 1.2	0.0027–0.135	0.1–5	C64444	GZn5.15
10 × 5	8.5 × 1	0.0027–0.135	0.1–5	C64444	GZn5.16
12 × 3	8.5 × 1	0.0027–0.135	0.1–5	C64444	GZn5.17
30 × 4.5	8.5 × 1	0.0027–0.135	0.1–5	C64444	GZn5.18
10 × 4	4 × 1.2	0.0027–0.135	0.1–5	C64444	GZn5.19
3 × 5	2.1 × 1.5	0.0027–0.135	0.1–5	C66444	GZn5.27

* — tolerance -10 ÷ +20 %

Other activities are available on request

Sources can be supplied complete with holders. For details see [page 20](#)

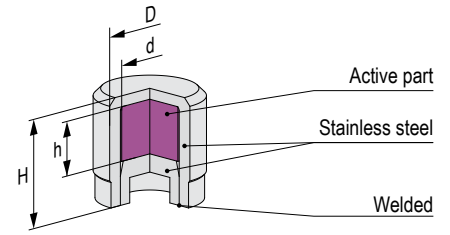

11

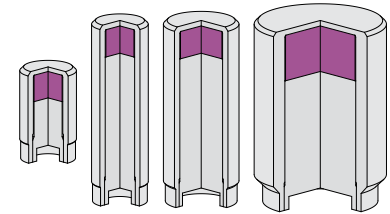
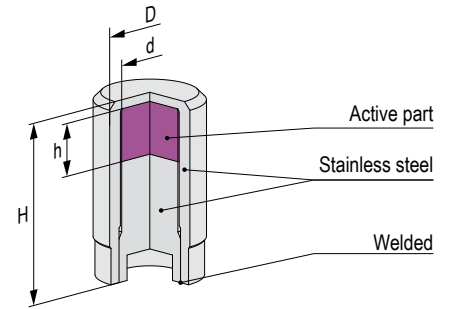

27 12 13 14

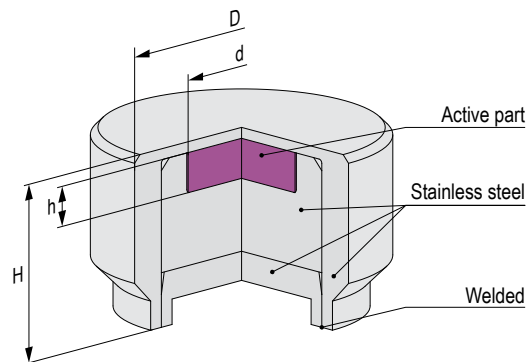

15

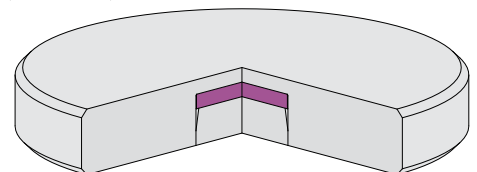
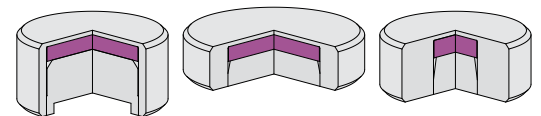
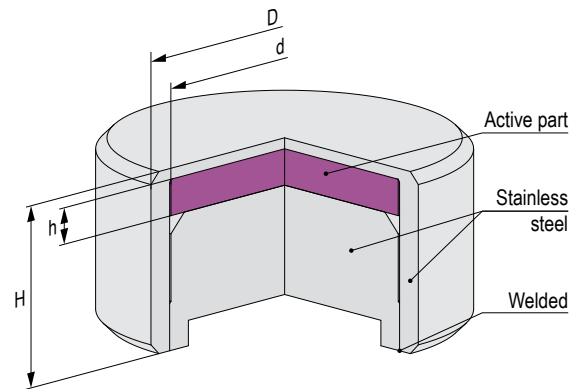

16 17 19

18

⁸⁸Y Gamma Sources

⁸⁸Y is incorporated in a light ceramic matrix and sealed in a welded stainless steel capsule. GY8.27 source is also available in titanium capsule.

Recommended working life: 15 years.

Certificates

IAEA Special Form Certificate No D/0098/S-96 (Rev.0) (for GY8.12, GY8.13, GY8.14, GY8.15, GY8.27)

D × H, mm	d × h, mm	Nominal activity *		ISO classification	Code
		mCi	MBq		
3 × 3	2.1 × 1.5	0.0027–0.027	0.1–1	C64344	GY8.11
3 × 10	2.1 × 1.5	0.0027–0.027	0.1–1	C64444	GY8.12
4 × 10	3.1 × 1.5	0.0027–0.027	0.1–1	C64444	GY8.13
7 × 10	5.2 × 2.5	0.0027–0.027	0.1–1	C64444	GY8.14
8 × 5	4 × 1.2	0.0027–0.027	0.1–1	C64444	GY8.15
10 × 5	8.5 × 1	0.0027–0.027	0.1–1	C64444	GY8.16
12 × 3	8.5 × 1	0.0027–0.027	0.1–1	C64444	GY8.17
30 × 4.5	8.5 × 1	0.0027–0.027	0.1–1	C64444	GY8.18
10 × 4	4 × 1.2	0.0027–0.027	0.1–1	C64444	GY8.19
3 × 5	2.1 × 1.5	0.0027–0.027	0.1–1	C66444	GY8.27

* — tolerance -10 ÷ +20 %

Other activities are available on request

Sources can be supplied complete with holders. For details see [page 20](#)

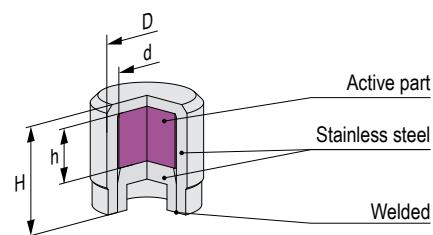

11

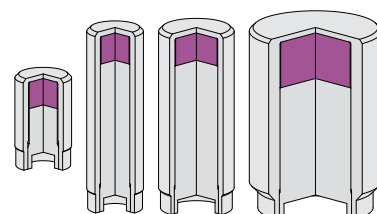
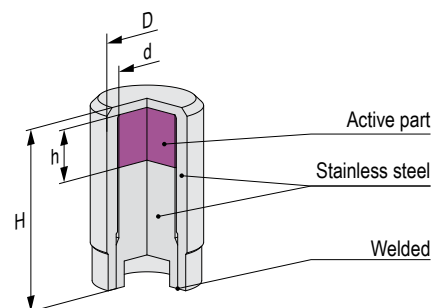

27 12 13 14

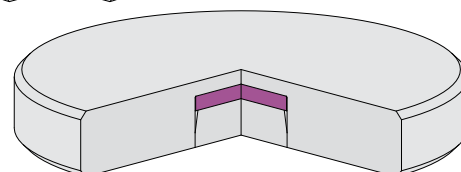
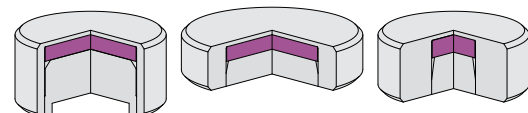
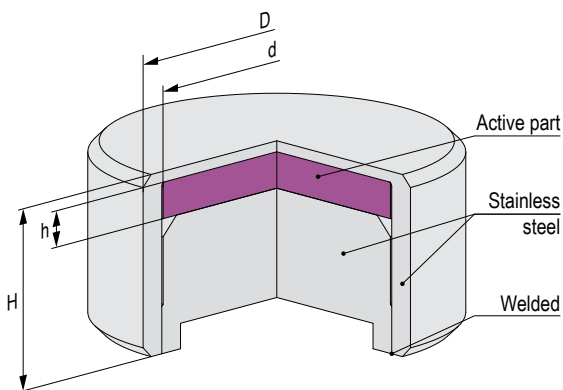

16 17 19
18

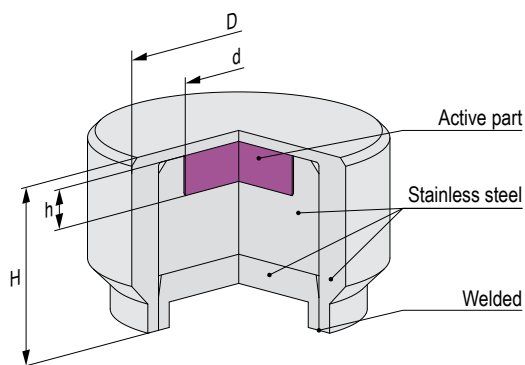

15

¹³³Ba Gamma Sources

¹³³Ba is incorporated in a light ceramic matrix and sealed in a welded stainless steel capsule. GBa3.27 source is also available in titanium capsule.
Recommended working life: 15 years.

Certificates

IAEA Special Form Certificate No D/0098/S-96 (Rev.0) (for GBa3.12, GBa3.13, GBa3.14, GBa3.15, GBa3.27)

D × H, mm	d × h, mm	Nominal activity *		ISO classification	Code
		mCi	MBq		
3 × 3	2.1 × 1.5	0.027–3	1–111	C64344	GBa3.11
3 × 10	2.1 × 1.5	0.027–3	1–111	C64444	GBa3.12
4 × 10	3.1 × 1.5	1–10	37–370	C64444	GBa3.13
7 × 10	5.2 × 2.5	1–10	37–370	C64444	GBa3.14
8 × 5	4 × 1.2	1–10	37–370	C64444	GBa3.15
10 × 5	8.5 × 1	1–10	37–370	C64444	GBa3.16
12 × 3	8.5 × 1	1–10	37–370	C64444	GBa3.17
30 × 4.5	8.5 × 1	1–10	37–370	C64444	GBa3.18
10 × 4	4 × 1.2	1–10	37–370	C64444	GBa3.19
3 × 5	2.1 × 1.5	0.027–3	1–111	C66444	GBa3.27

* — tolerance -10 ÷ +20 %

Other activities are available on request

Sources can be supplied complete with holders. For details see [page 20](#)

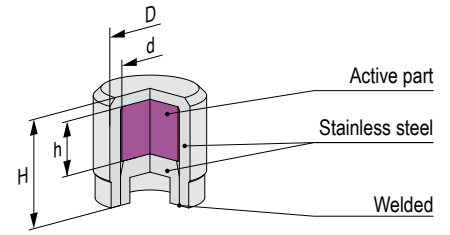

11

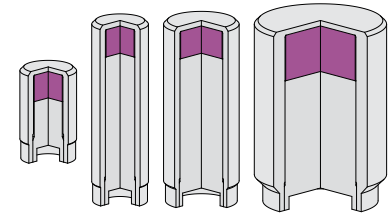
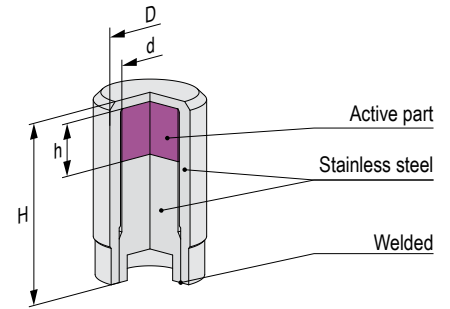

27 12 13 14

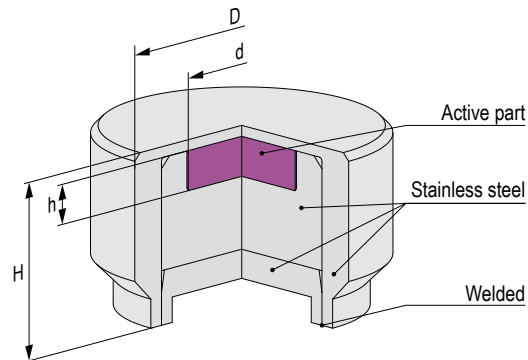

15

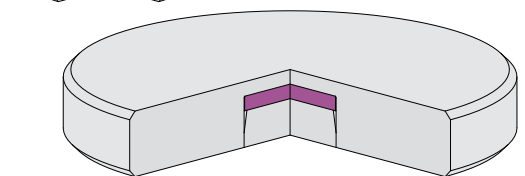
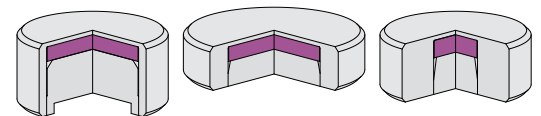
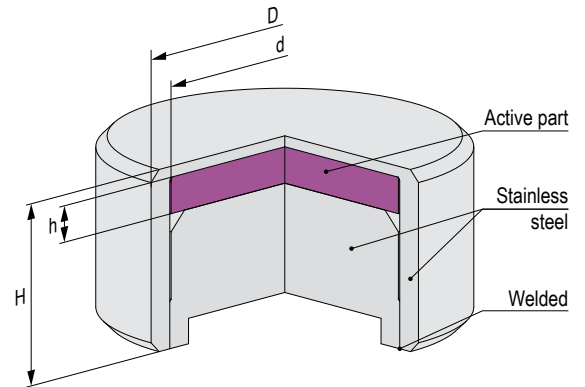

16 17 19
18

¹³⁷Cs Gamma Sources

¹³⁷Cs is incorporated in a light ceramic matrix and sealed in a welded stainless steel capsule. GCs7.27 source is also available in titanium capsule.

Recommended working life: 15 years.

Certificates

IAEA Special Form Certificate No D/0098/S-96 (Rev.0) (for GCs7.12, GCs7.13, GCs7.14, GCs7.15, GCs7.27)

D × H, mm	d × h, mm	Nominal activity *		ISO classification	Code
		mCi	MBq		
3 × 3	2.1 × 1.5	0.0027–0.135	0.1–5	C64344	GCs7.11
3 × 10	2.1 × 1.5	0.0027–0.135	0.1–5	C64444	GCs7.12
4 × 10	3.1 × 1.5	0.0027–0.135	0.1–5	C64444	GCs7.13
7 × 10	5.2 × 2.5	0.0027–0.135	0.1–5	C64444	GCs7.14
8 × 5	4 × 1.2	0.0027–0.135	0.1–5	C64444	GCs7.15
10 × 5	8.5 × 1	0.0027–0.135	0.1–5	C64444	GCs7.16
12 × 3	8.5 × 1	0.0027–0.135	0.1–5	C64444	GCs7.17
30 × 4.5	8.5 × 1	0.0027–0.135	0.1–5	C64444	GCs7.18
10 × 4	4 × 1.2	0.0027–0.135	0.1–5	C64444	GCs7.19
6 × 10	4 × 6.1	0.0027–0.135	0.1–5	C65546	GCs7.26**
3 × 5	2.1 × 1.5	0.0027–0.135	0.1–5	C66444	GCs7.27
6 × 9.5	3 × 4	0.0058–0.23	0.215–8.5	C66546	GCs7.46**

* — tolerance -10 + +20 %

** — for details see [page 19](#)

Other activities are available on request

Sources can be supplied complete with holders. For details see [page 20](#)

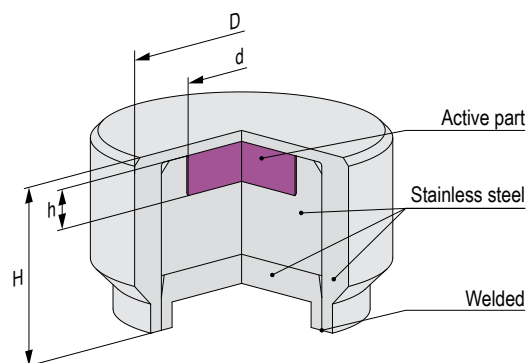

15

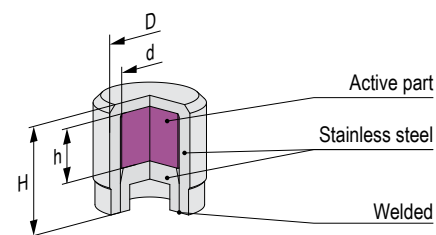

11

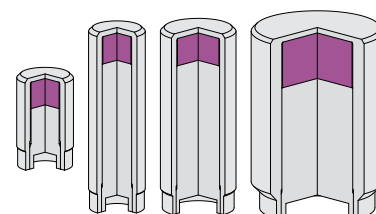
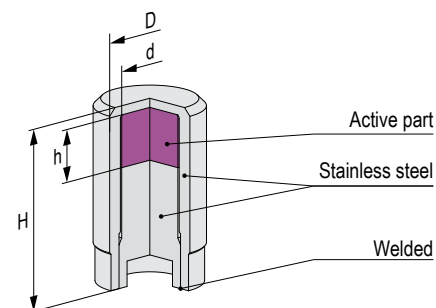

27 12 13 14

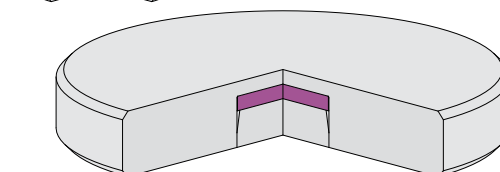
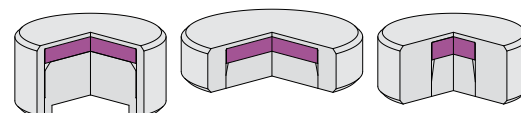
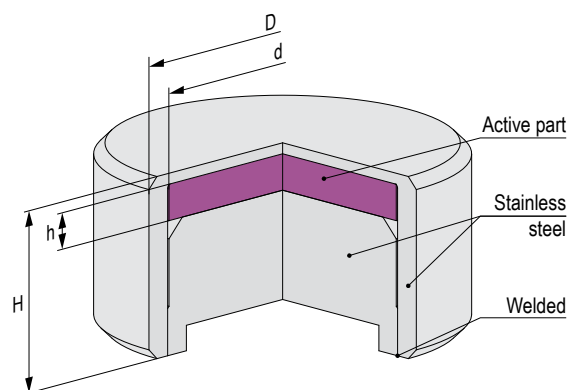

16 17 19
18

¹⁵²Eu Gamma Sources

¹⁵²Eu is incorporated in a light ceramic matrix and sealed in a welded stainless steel capsule. GEu2.27 source is also available in titanium capsule.
Recommended working life: 15 years.

Certificates

IAEA Special Form Certificate No D/0098/S-96 (Rev.0) (for GEu2.12, GEu2.13, GEu2.14, GEu2.15, GEu2.27)

D × H, mm	d × h, mm	Nominal activity *		ISO classification	Code
		mCi	MBq		
3 × 3	2.1 × 1.5	0.0027–0.135	0.1–5	C64344	GEu2.11
3 × 10	2.1 × 1.5	0.0027–0.135	0.1–5	C64444	GEu2.12
4 × 10	3.1 × 1.5	0.0027–0.135	0.1–5	C64444	GEu2.13
7 × 10	5.2 × 2.5	0.0027–0.135	0.1–5	C64444	GEu2.14
8 × 5	4 × 1.2	0.0027–0.135	0.1–5	C64444	GEu2.15
10 × 5	8.5 × 1	0.0027–0.135	0.1–5	C64444	GEu2.16
12 × 3	8.5 × 1	0.0027–0.135	0.1–5	C64444	GEu2.17
30 × 4.5	8.5 × 1	0.0027–0.135	0.1–5	C64444	GEu2.18
10 × 4	4 × 1.2	0.0027–0.135	0.1–5	C64444	GEu2.19
3 × 5	2.1 × 1.5	0.0027–0.135	0.1–5	C66444	GEu2.27

* — tolerance -10 ÷ +20 %

Other activities are available on request

Sources can be supplied complete with holders. For details see [page 20](#)

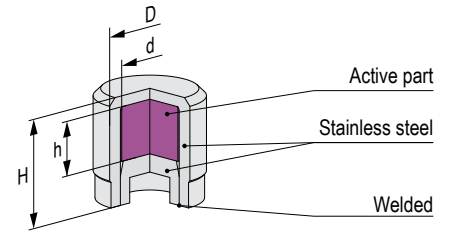

11

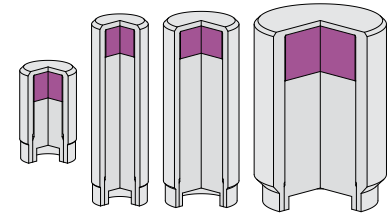
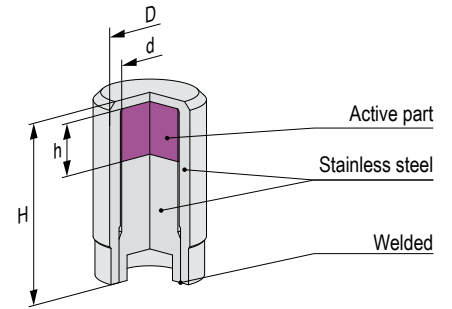

27 12 13 14

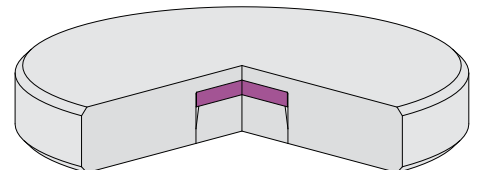
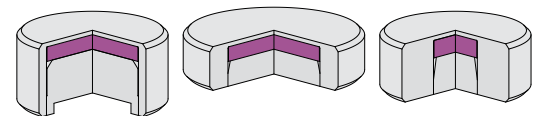
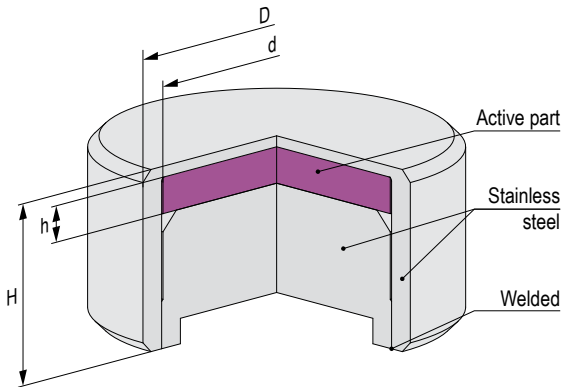

16 17 19
18

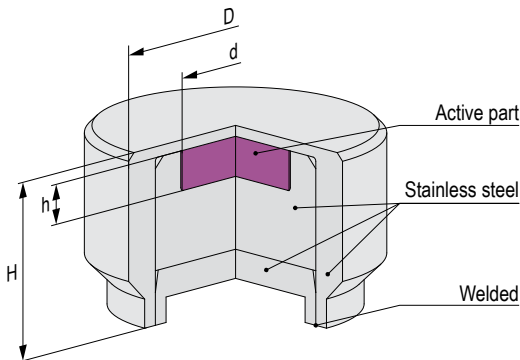

15